

BUCHER
DESIGN STUDIO
architecture • planning

12325 Oracle Blvd. Suite 101
Colorado Springs, CO 80921
(719) 484-0480

Brian K. Bucher, AIA
Architect
CO license no. C-4889

A NEW
BUILDING
FOR

WIDFIELD
COMMUNITY
BIBLE CHURCH

702 QUEBEC ST
COLORADO SPRINGS, CO 80911

Sheet Title:
**SITE
SIGN PLAN**

Drawing Status:
SDP SUBMITTAL

NOT FOR CONSTRUCTION

Revisions:
No. Description By Date

No.	Description	By	Date

All ideas, designs, arrangements and plans indicated or represented by this drawing are owned by and the property of BUCHER DESIGN STUDIO and were created, evolved and developed for use on, and in conjunction with, the specified project. None of such design, arrangements or plans shall be used by, or disclosed to any person, firm or corporation for any purpose whatsoever without the written permission of BUCHER DESIGN STUDIO.

Date: 9/30/24

Drawn by:

Checked by:

Scale: AS NOTED

Job No.:

Sheet No.:
A0.1
Of



1 EXIST, MONUMENT SIGN
NO SCALE

- Please indicate the height and width of the sign so we can determine the area of the sign.
- If the sign is illuminated, please indicate how the proposed illumination is in compliance with the lighting standards.

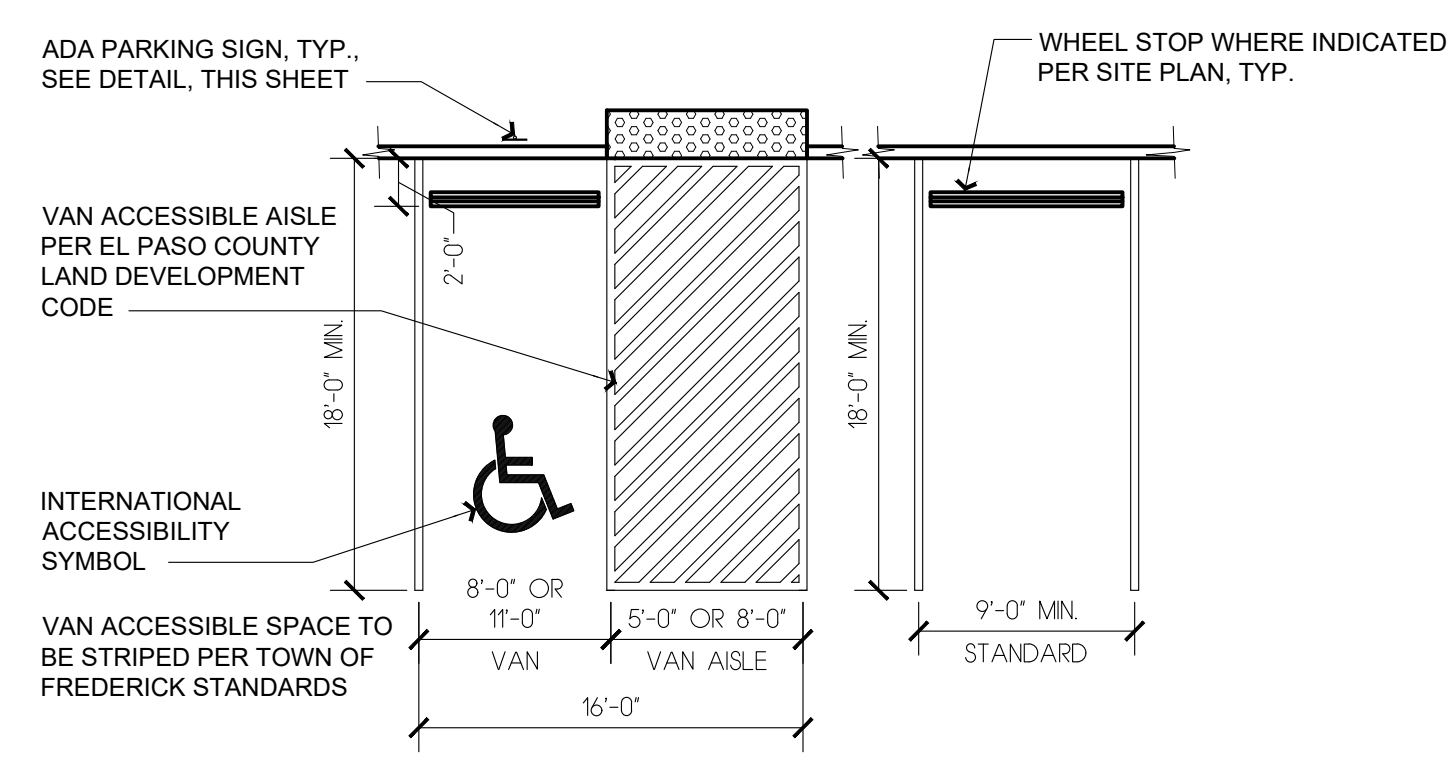

PARKING SIGNS: EACH ACCESSIBLE PARKING SPACE SHALL BE DESIGNATED AS RESERVED BY A SIGN SHOWING THE SYMBOL OF ACCESSIBILITY (A WHEELCHAIR). EACH SIGN SHALL BE NO SMALLER THAN ONE FOOT BY ONE FOOT (1' X 1') AND SHALL BE LOCATED AT THE END OF THE SPACE AT A HEIGHT BETWEEN FOUR (4') AND SEVEN FEET (7'). THE SIGN MAY EITHER BE WALL MOUNTED OR FREESTANDING.

2 ACCESSIBLE PARKING
SCALE: 1/8" = 1'-0"

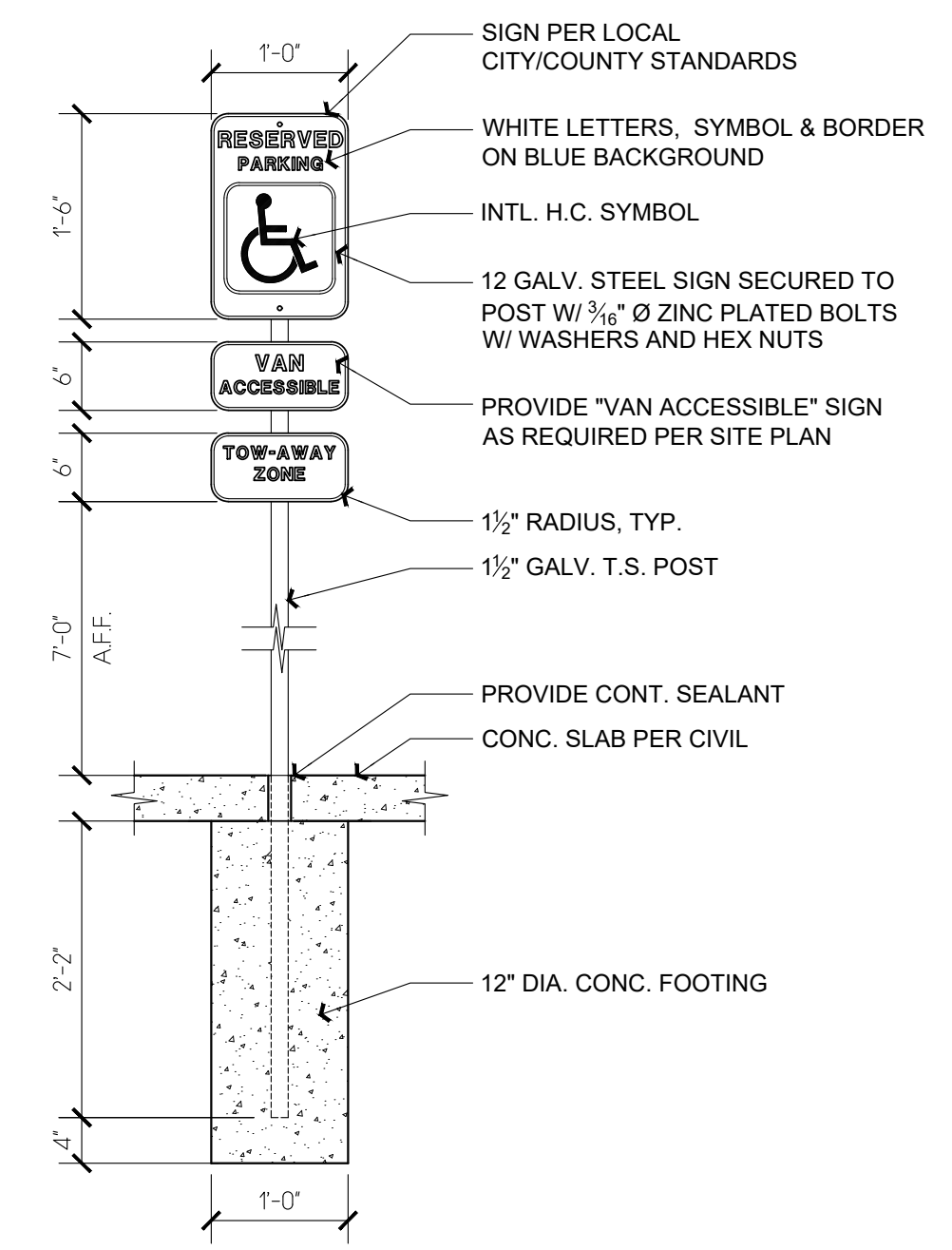

3 ACCESSIBLE SIGN
SCALE: 3/4" = 1'-0"

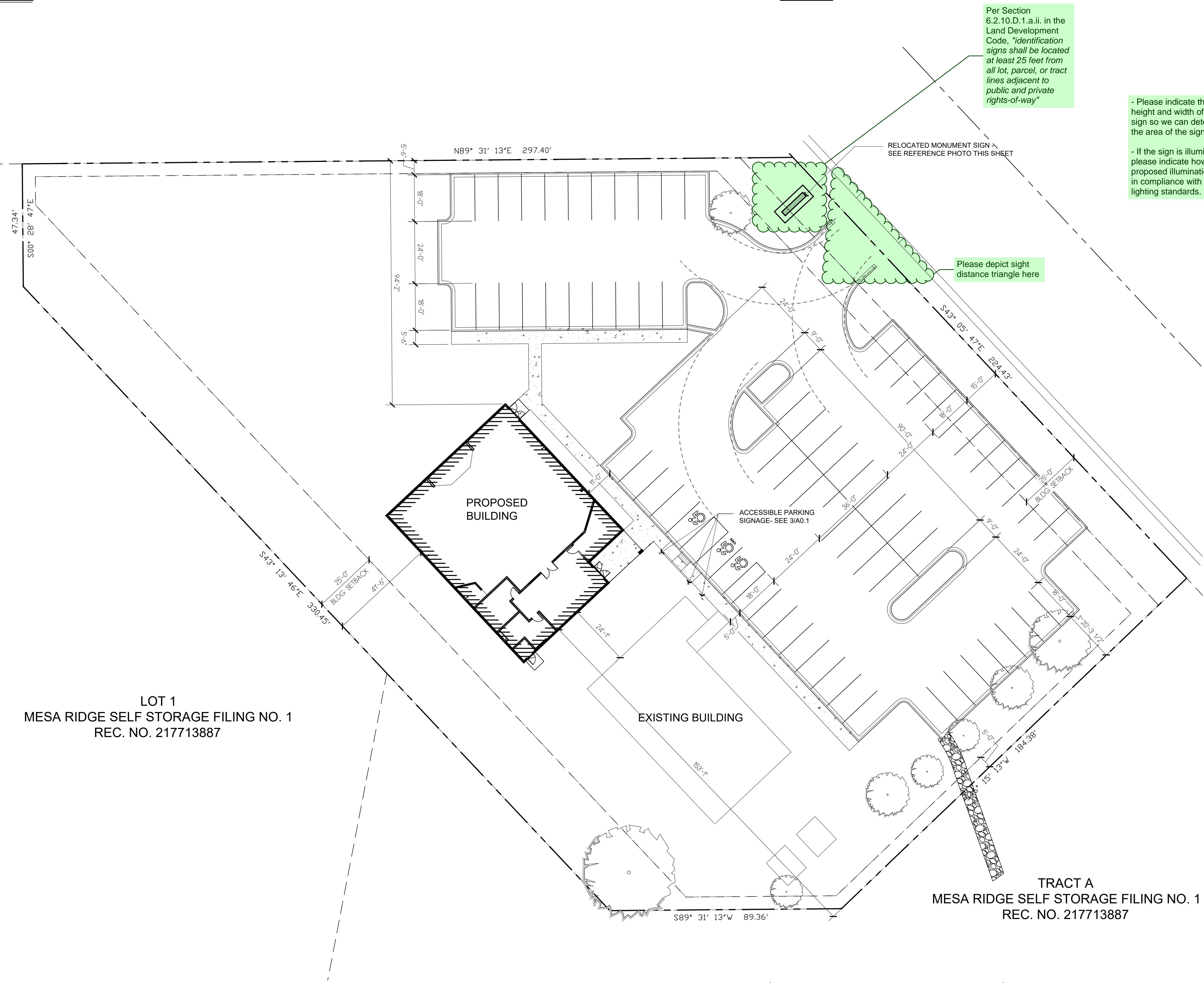

LOT 1
MESA RIDGE SELF STORAGE FILING NO. 1
REC. NO. 217713887

TRACT A
MESA RIDGE SELF STORAGE FILING NO. 1
REC. NO. 217713887

Per Section 6.2.10.D.1.a.ii. in the Land Development Code, "identification signs shall be located at least 25 feet from all lot, parcel, or tract lines adjacent to public and private rights-of-way"

Please depict sight distance triangle here

RELOCATED MONUMENT SIGN - SEE REFERENCE PHOTO THIS SHEET

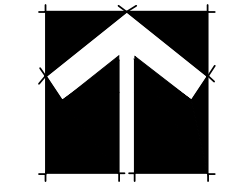

SITE SIGN PLAN
SCALE: 1" = 20'-0"

PPR2438